

MAGNUS OLESEN

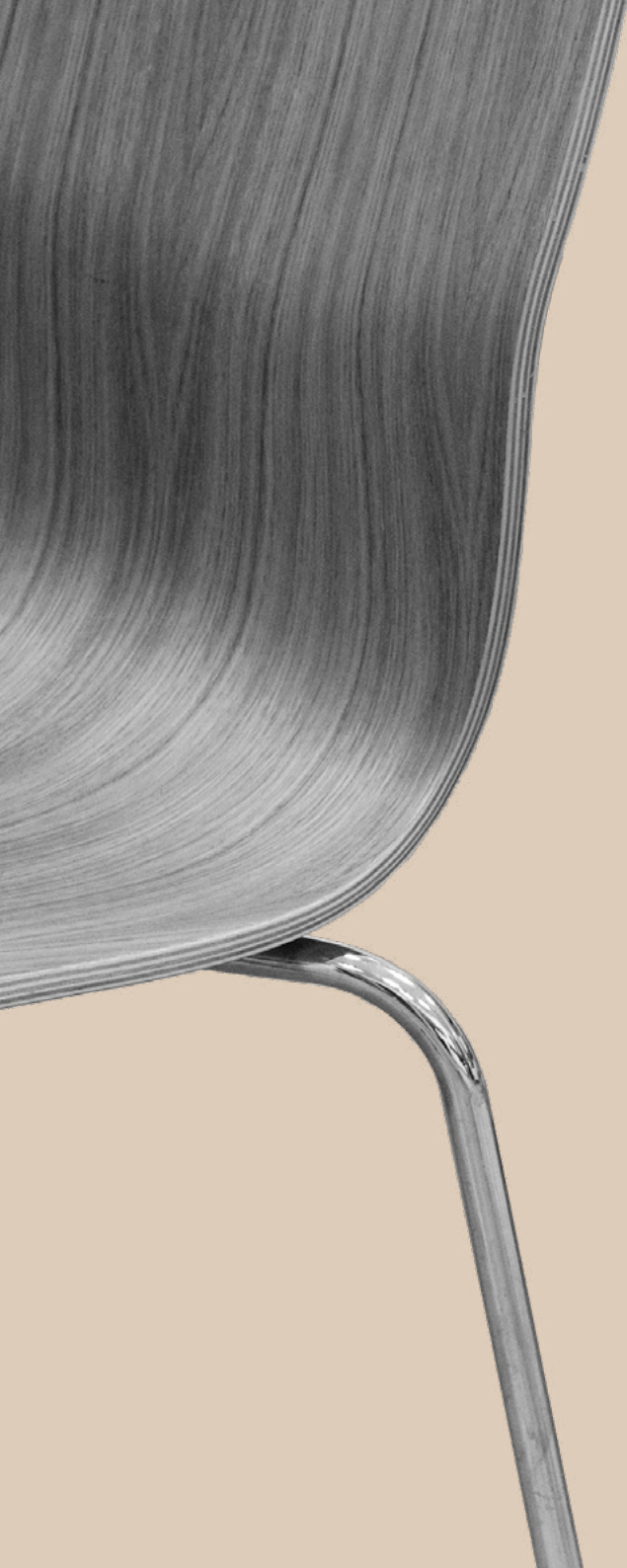

CARE



INDEKS

Magnus Olesen Care	05
Bæredygtighed / Sustainability	08
Take Back	12
Care Interior	14
Produkter / Products	72

Butterfly Chair



MAGNUS OLESEN CARE

Med vores høje kvalitetsstandarder og historik med hensyn til de særlige behov inden for Care, er en række af vores produkter velegnet til Care-markedet. Derudover er en række af vores møbler designet specielt til Care-segmentet. Produkterne er udviklet i tæt samarbejde med brugere (brugerdrevet design) samt arkitekter og interiørdesignere specialiseret inden for segmentet. Der lægges særlig vægt på krav til hygiejne, hård brug, sikkerhed, stabilitet og holdbarhed af møblerne uden at gå på kompromis med komfort og æstetik.

Det er Magnus Olesens ambition at lave møbler, der ikke alene lever op til de høje kvalitetskrav, der stilles i områder med intensivt brug og varierende brugssituationer, men også tager højde for sundhedssektorens særlige behov.

Her er der særlig fokus på hygiejne og rengøring, og Magnus Olesen arbejder løbende på optimering af disse to forhold. Overfladerne skal kunne modstå afsprøjtning og helst være bakteriehæmmende. Magnus Olesen arbejder derfor i overvejende grad med træ, linoleum og PUR – materialer, der alle har en bakteriehæmmende effekt.

Størstedelen af produkterne er dekomponerbare, og f.eks. et sæde/sædebetræk, en ryg eller et armlæn kan derfor om nødvendigt hurtigt udskiftes, således at møblerne konstant vil kunne være i brug og deres levetid forlænges yderligere.

Møblerne skal også understøtte de særlige krav, der er på dette område i forbindelse med brugernes komfort og tryghed - møblernes ergonomi og stabilitet. Vi har derudover særligt fokus på, at møblernes visuelle kvalitet opleves som noget ganske særligt. Møblerne er designet til at være langtidsholdbare, både i styrkemæssig henseende og i forhold til den arkitektur, de indgår i.



Pause Chair



MAGNUS OLESEN CARE

With our high quality standards and history of consideration of the special needs within Care, a variety of our products are suitable for the Care market. In addition a number of products have been especially designed for the Care segment. The products are developed in close collaboration with users (user-driven design) as well as architects and interior designers specialized within the segment. Special attention is paid to demands on hygiene, heavy use, safety, stability and durability of the furniture, without compromising on comfort and aesthetics.

The ambition of Magnus Olesen is to manufacture furniture which does not only meet the high demands for quality required in areas with intensive and varying use, but also takes into consideration the special needs within the Care sector.

Within this area special attention is paid to hygiene and cleaning, and Magnus Olesen is continuously striving to optimise performance within these two areas. The surfaces must withstand disinfection and preferably be anti-bacterial. This is why Magnus Olesen mainly works with wood, linoleum and PUR-rubber, all with anti-bacterial properties.

The major part of our Care sector products are made for disassembly and so, if necessary, parts like a seat/seat cover, back support or an arm rest can easily be exchanged, in order for the furniture to be in constant use and ensuring that the lifetime of the products is further extended.

All our Care products are manufactured to support the special demands of our customers in this sector with respect to ergonomics, comfort, safety and stability. Magnus Olesen's particular concern is that the visual aesthetics of the furniture are regarded as something out of the ordinary. Our furniture is designed to be durable, both with respect to strength and in relation to the architecture of which it is a part of.



Butterfly Chair



BÆREDYGTIGHED

DE GRUNDLÆGGENDE ELEMENTER I VORES PRODUKTER ER NATURLIGE MATERIALER SOM TRÆ, LINOLEUM, LÆDER OG ULD.

PRODUKTION I DANMARK

Vi tror på det danske håndværk og har produceret i Danmark helt siden 1937. Træ og andre råvarer omdannes til stole og borde lokalt i Danmark. Med vores fabrik i Danmark arbejder vi målrettet for en produktion, der lever op til de skrappeste miljøkrav.

ANSVARLIGT FORBRUG AF MATERIALER

Magnus Olesens produktion er baseret på bæredygtige materialer. Siden 2016 har Magnus Olesen været FSC®-certificeret (FSC-C131817).

Vores miljøvalg gælder ikke kun vores træ, men også andre materialer i vores produktion. Vi arbejder f.eks. med trivalent krom som er miljøcertificeret. En række af vores borde er lavet af Honeycomb-materiale som minimerer materialeforbruget, og gør bordene lette og nemme at håndtere.

CIRKULÆR ØKONOMI/ DESIGN FOR DISASSEMBLY/ TAKE BACK

Vi arbejder med cirkulær økonomi og hovedparten af vores produkter er designet med henblik på adskillelse, så de er nemme at genbruge og recycle.

KLIMAKLAR PRODUKTIONSVIRKSOMHED

I 2024 afsluttede Magnus Olesen programmet 'KLIMAKLAR – CLIMATE-FIT MANUFACTURING COMPANY'. Et initiativ af DI – Dansk Industri, der hjælper danske produktionsvirksomheder med at få indsigt i CO₂-kortlægning og at udarbejde målrettede reduktionstiltag for at nå klimamålene.

Programmet understøtter den grønne omstilling og hjælper virksomheder med at deltage i det overordnede mål om at gøre Danmark til verdens første klimaneutrale produktionsindustri.

[Se certifikater og få mere information på \[magnusolesen.dk/da/baeredygtighed\]\(https://magnusolesen.dk/da/baeredygtighed\)](https://magnusolesen.dk/da/baeredygtighed)

KLIMAKLAR

PRODUKTIVSVIRKSOMHED

Ø Chair



SUSTAINABILITY

THE BASIC ELEMENTS OF OUR PRODUCTS ARE NATURAL MATERIALS
SUCH AS WOOD, LINOLEUM, LEATHER AND WOOL.

PRODUCTION IN DENMARK

We believe in Danish craftsmanship and have produced in Denmark ever since 1937. Wood and other raw materials are converted into chairs and tables locally in Denmark. With our factory in Denmark we work purposefully for a production that meets the strictest environmental requirements.

RESPONSIBLE USE OF MATERIALS

Magnus Olesen's production is based on sustainable materials. Since 2016, Magnus Olesen has been FSC® certified (FSC-C131817). Our environmental choices apply not only to our wood but also to other materials in our production. E.g. we work with trivalent chrome which is environmentally certified. A variety of our tables are made with Honeycomb material: minimizing the use of material, making the tables lightweight and easy to handle.

CIRCULAR ECONOMY/ DESIGN FOR DISASSEMBLY/ TAKE BACK

We work with circular economy and the majority of our products are designed for disassembly making them easy to recycle and reuse.

CLIMATE-FIT MANUFACTURING COMPANY

In 2024 Magnus Olesen completed the program 'KLIMAKLAR – CLIMATE-FIT MANUFACTURING COMPANY'. An initiative by DI – Dansk Industri, that enables Danish production companies to gain insights into the use of CO2 mapping and to prepare targeted reduction measures to achieve climate objectives. It supports green transitioning and helps companies to participate in the overall goal of making Denmark the world's first climate neutral manufacturing industry.

[For certificates and more information visit \[magnus-olesen.com/sustainability\]\(https://magnus-olesen.com/sustainability\)](https://magnus-olesen.com/sustainability)



BRUGT PRODUKT RETURNERES
// RETURN OF USED PRODUCT

PRODUKT OPGRADERES PÅ VORES
FABRIK I DANMARK
// THE PRODUCT IS UPGRADED AT OUR
FACTORY IN DENMARK

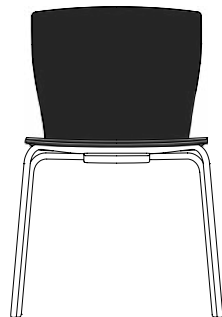

OPGRADERET PRODUKT MED FORLÆNGET LEVETID
// UPGRADED PRODUCT WITH EXTENDED LIFESPAN

TAKE BACK

/ Magnus Olesen producerer med udgangspunkt i Danmark kvalitetsmøbler, der er tiltænkt et langt liv. Vi arbejder med bæredygtighed, social ansvarlighed og cirkulær økonomi som væsentlige elementer i virksomhedens forretningsstrategi. Magnus Olesen ønsker at tage ansvar for det omgivende miljø og medarbejdere i produktionsprocessen såvel som produkterne i hele deres livscyklus – fra at produktet er nyt og til det endeligt dekomponeres og bortskaffes. Et langt liv og komponenter, der er baseret på ædle materialer, som kan dekomponeres, medvirker til reduktion af miljøbelastningen.

Produkterne er designet af ledende designere med sigte på at gøre designet langtidsholdbart, men også med henblik på at produkterne kan skilles ad, så sliddele kan udskiftes til glæde for miljøet.

I forbindelse med køb af Magnus Olesen produkter tilbyder Magnus Olesen mulighed for en "take back" aftale på de indkøbte kvalitetsmøbler.

// Based in Denmark, Magnus Olesen produces quality furniture that is intended for a long life. We work with sustainability, social responsibility and circular economy as essential elements of the company's business strategy. Magnus Olesen wants to take responsibility for the surrounding environment and employees in the production process as well as the products throughout their life cycle - from the product being new and until it is finally decomposed and disposed of. A long life and components based on precious decomposable materials help to reduce the environmental impact.

The products are designed by leading designers with focus on making the design long-lasting as well as easy to disassemble so that parts can be replaced which benefits the environment in the long run.

In connection with the purchase of Magnus Olesen products, we offer the possibility of a "take back" agreement on the quality furniture purchased.



CARE INTERIORS

Se vores seneste referencer, hvor en række Magnus Olesen-produkter bringes til live og anvendes i sundheds-segmentet.

See our latest references where a variety of Magnus Olesen products are brought to life and are used in health- and care segment interiors.

SUNDHEDSCENTER

CENTER FOR DIABETES OG
HJERTESYGDOMME

/

CENTER FOR BØRN OG UNGES
SUNDHED

Hans Kirk Vej, Copenhagen,
Denmark

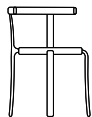

8000 SERIES CHAIR
MIX TABLE





















VENTEVÆRELSE

SUNDHEDENS HUS

Aalborg, Denmark

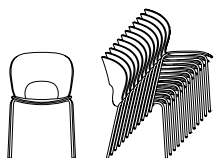

Ø CHAIR





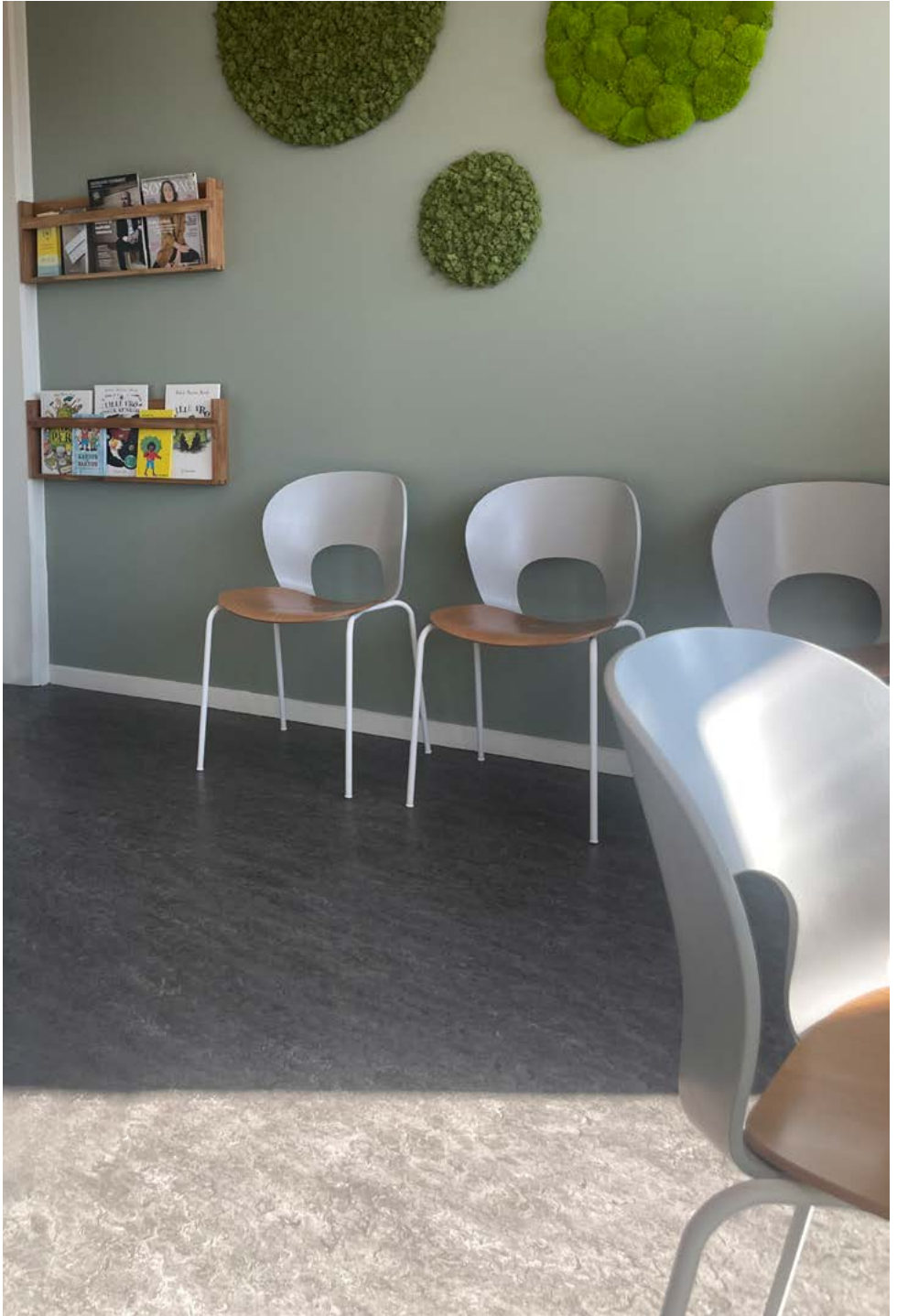



GENTOFTE HOSPITAL

Gentofte, Denmark



BUTTERFLY, SOLACIA,
SESSION RELAX















BISPEBJERG HOSPITAL

Bispebjerg, Denmark

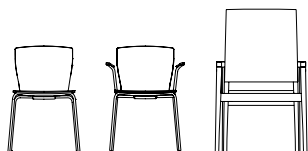

BUTTERFLY, BUTTERFLY W. ARM,
SESSION RELAX







HOSPITAL SØNDERBORG

Sønderborg, Denmark



FREYA LOUNGE, TRIO TABLE,
FREYA W. ARM, FREYA,
MIX TABLE W. FOLDING LEG













HOSPITAL AABENRAA

Aabenraa, Denmark



FREYA, MIX TABLE,
FREYA W. ARM, TRIO TABLE
FREYA LOUNGE

















PLASTIKKIRURGEN SABROE EBBESEN

Copenhagen, Denmark



8000 SERIES CHAIR
PAUSE, PAUSE W. ARM







← toilet









LOUISE MARIE NURSING HOME

COPENHAGEN, DENMARK

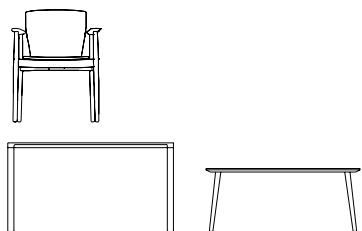

BUTTERFLY CLASSIC CHAIR,
SLENDER TABLE, TRIO TABLE





bread









JÆGERSBORGHAVE NURSING HOME

Gentofte, Denmark

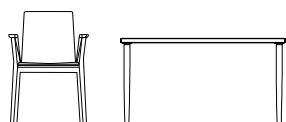

TONICA WOOD,
MIX TABLE W. FOLDING LEGS









SELECTED CARE PRODUCTS

OVERSIGT OVER PRODUKTER SÆRLIGT
EGNET CARE INDRETNINGER

OVERVIEW OF PRODUCTS ESPECIFICALLY
SUITABLE FOR CARE INTERIORS

8000 Series
Butterfly Series
Ø Chair
Session Series
Tonica Wood
Freya Series
45-Series
Pause Series
Solacia
Addi Meeting
Trio Coffee Table
Slender Table
Folding Legs
Mix Table
Brunch Table

8000 Series

Designer: Rud Thygesen & Johnny Sørensen

MO 8002 Stacks 6

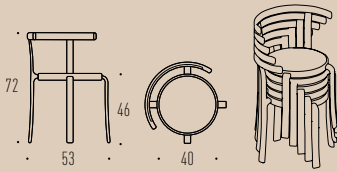

Butterfly Classic Chair

Designer: Niels Gammelgaard

MO 5351

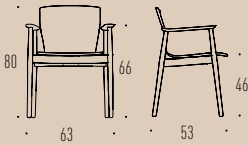

Butterfly Classic Lounge & Butterfly Classic Sofa

Designer: Niels Gammelgaard

MO 5369, MO 5379 MO 5381, MO 5391

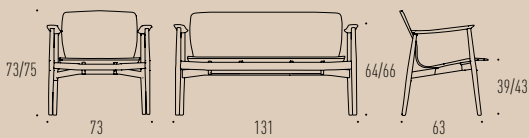

Butterfly

Designer: Niels Gammelgaard

MO 5310 Stacks 12

MO 5311

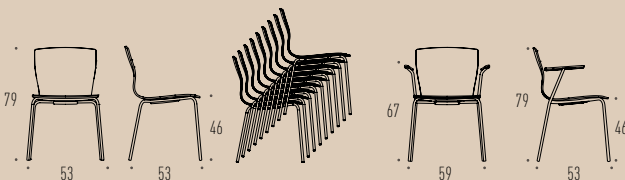

Ø Chair

Designer: Øivind Slaatto

MO 2030 Stacks 12

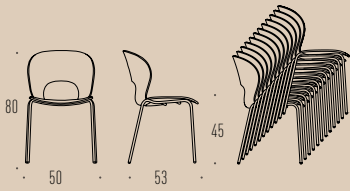

Session

Designer: busk+hertzog

MO 9401 Stacks 10

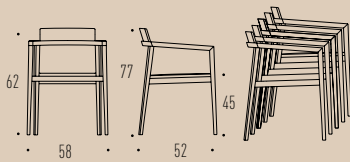

Session Relax

Designer: busk+hertzog

MO 9406 Stacks 6

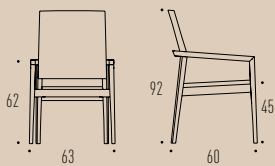

Tonica Wood

Designer: Niels Gammelgaard

MO 5330 Stacks 9, w. polster 6

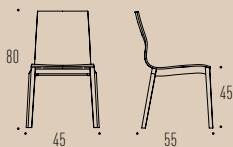

MO 5331 Stacks 9, w. polster 6

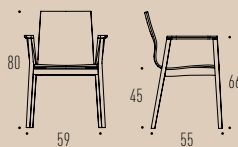

Freya & Freya Lounge

Designer: Says Who

MO 4711

MO 4731

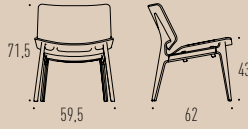
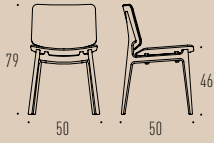

Freya w. Arm

Designer: Says Who

MO 4714 Stacks 6

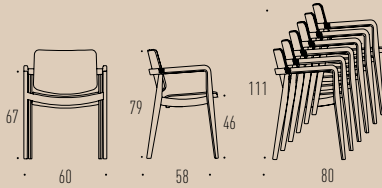

Freya Coffee Table

Designer: Says Who

MO 4770-1, MO 4770-2, MO 4770-3, MO 4770-4

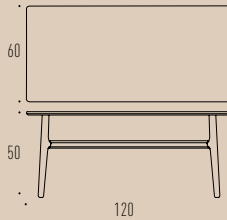
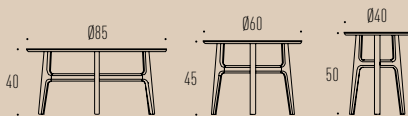

45-Series

Designer: Rud Thygesen & Johnny Sørensen

MO 4554 Stacks 8

MO 4564 Stacks 8

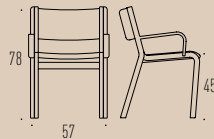
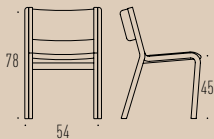

Pause

Designer: busk+hertzog

MO 8661 Stacks 10

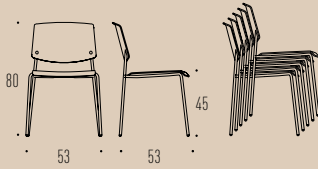

Pause w. Arm

Designer: busk+hertzog

MO 8662 Stacks 10

MO 8653

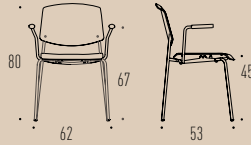
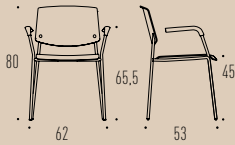

Solacia

Designer: Lone Storgaard

MO 8473

MO 8470

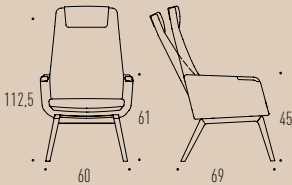

Addi Meeting

Designer: Friis & Moltke

MO 5354 MO 5356 MO 5357

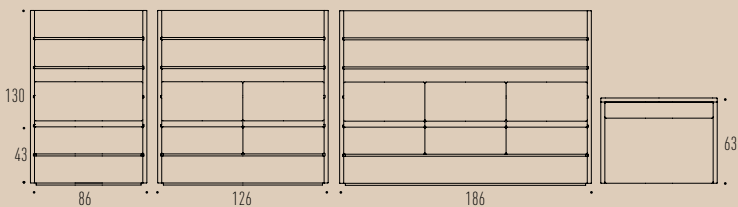

Trio Coffee Table

MO 9580-6, MO 9580-5, MO 9580-4

MO 9580-3 & MO 9580-2

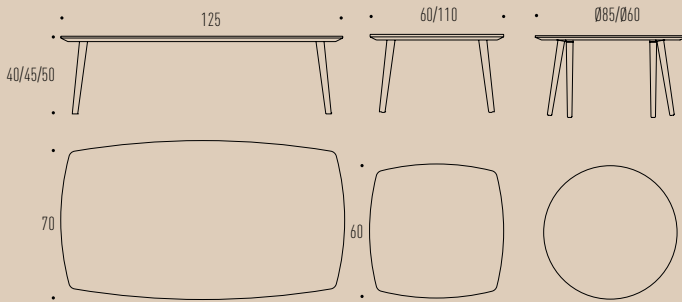

Slender

Designer: Antonio Scaffidi

MO 7100

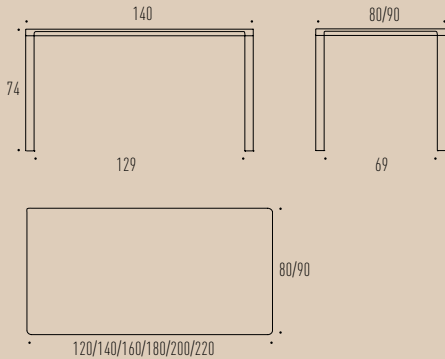

Folding Legs

Available with Mix & Brunch table

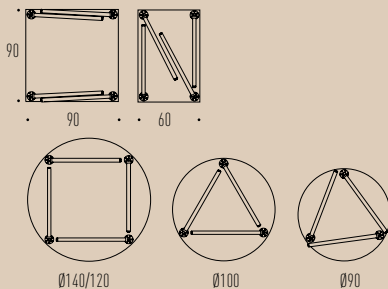

Mix Table

Designer: Rud Thygesen & Johnny Sørensen

MO 7003 MO 7020, MO 7021, MO 7007, MO 7009 MO 7030, MO 7031

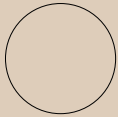
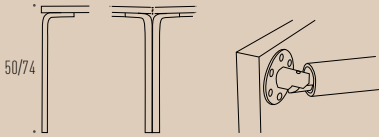
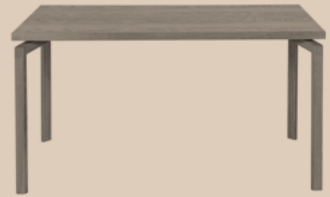
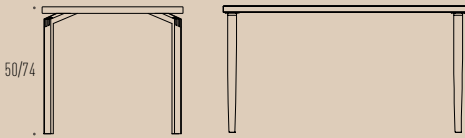

Ø80/90/108/120/140

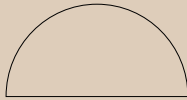

120/140/160/180



70 R80/ 80 R90/ 90 R100/ 108 R118



80/90/108

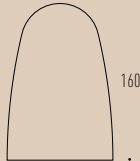

160

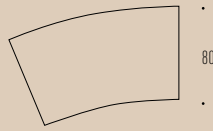

80

80/90/108/120/140/
160/180/200/210

108

Brunch Table

Designer: Pelikan Design

MO 6671+6676 MO 6665+6667

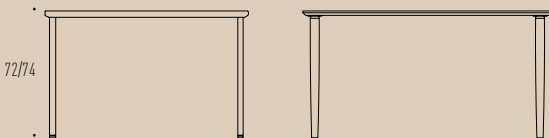

72/74

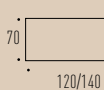

120/140

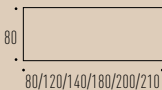

80/120/140/180/200/210

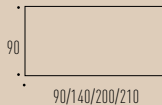

90/140/200/210

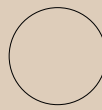

Ø 90/120

CONTACT

post@magnus-olesen.dk

magnus-olesen.com



SHOWROOM

Frederiksgade 7
1265 Copenhagen
Denmark

FACTORY

Agertoft 2, Durup
7870 Roslev
Denmark



MAGNUS OLESEN